

Global Stainless Steel Cycle Exemplifies China's Rise to Metal Dominance

BARBARA K. RECK,^{*,†}
MARINE CHAMBERON,[†]
SEIJI HASHIMOTO,^{†,‡} AND
T. E. GRAEDEL[†]

Center for Industrial Ecology, Yale University, New Haven, CT, and
National Institute for Environmental Studies, Tsukuba, Japan

Received November 25, 2009. Revised manuscript received
March 25, 2010. Accepted April 8, 2010.

The use of stainless steel, a metal employed in a wide range of technology applications, has been characterized for 51 countries and the world for the years 2000 and 2005. We find that the global stainless steel flow-into-use increased by more than 30% in that 5 year period, as did additions to in-use stocks. This growth was mainly driven by China, which accounted for almost half of the global growth in stainless steel crude production and which tripled its flow into use between 2000 and 2005. The global stainless steel-specific end-of-life recycling rate increased from 66% (2000) to 70% (2005); the landfilling rate was 22% for both years, and 9% (2000) to 12% (2005) was lost into recycled carbon and alloy steels. Within just 5 years, China passed such traditionally strong stainless steel producers and users as Japan, USA, Germany, and South Korea to become the dominant player of the stainless steel industry. However, China did not produce any significant stainless steel end-of-life flows in 2000 or 2005 because its products-in-use are still too new to require replacements. Major Chinese discard flows are expected to begin between 2015 and 2020.

1. Introduction

The growing interest in metal life cycles stems from the basic idea that before optimizing a complex system all of its aspects need to be fully understood. Metals are core materials of the industrialized world and essential to maintaining our modern lifestyle. Their use has grown exponentially over the past century (1) and continues to grow as increasing numbers of countries strive for technological development and higher living standards. Although there are indications that the demand for metals may slow or stabilize in mature economies (2), this is not the case in rapidly growing emerging economies such as China and India. From an environmental perspective, an increased demand for metals typically means more mining, energy use (3, 4), and water consumption (5). Conversely, when scrap is used as a raw material, the energy requirements of metal production can be lowered significantly (6). Understanding the current and future scrap supply is, therefore, a key goal if the use of primary metals is to be reduced.

Comprehensive anthropogenic metal life cycles provide quantitative information on how different regions use

metals at various life stages, on the related trade flows that enable the global economy, and on current and future scrap availability. Over the past decade, several metals have been characterized at various spatial and temporal levels, e.g., copper (7–9), zinc (10, 11), aluminum (12, 13), tungsten (14), and cadmium (15). These studies show that the mining of metals usually takes place in countries other than those fabricating, manufacturing, and using metals, indicating that many resource-rich countries export their primary metals to more industrialized countries rather than processing them domestically. They also show that the majority of metals extracted over the past century is still in use, underlining the importance of efficient recovery at end of service.

Stainless steels are corrosion-resistant, high-performance alloys that are used for specialty applications in industry (e.g., chemical, pharmaceutical), transportation, buildings, and in consumer applications. Global and country-level studies exist for the main alloying elements of stainless steel: iron (16, 17), chromium (18), and nickel (19). At the country level, two dynamic stainless steel studies for Japan illustrate how different chemical grades of stainless steel impact current and future scrap availability (20, 21). Data from these studies were also the basis for an investigation into the efficiency of stainless steel use and reuse in Japan (22).

The present study addresses the stainless steel cycle at various spatial levels for the years 2000 and 2005. It is the first study to (i) characterize at the global level the cycle for stainless steel (or any alloy), and to (ii) analyze at the global level the dynamics of a metal market during the early 20th century. Although the stainless steel family includes a large number of different alloys, typically classified into austenitic (with nickel), ferritic (without nickel), martensitic, and duplex grades (23–25), we treat all of the alloys in aggregate for reasons of data availability. The study covers 51 countries, country groups, and territories, including such traditionally strong stainless steel markets as Japan, Western Europe, and USA and emerging economies such as China, India, and Brazil.

2. Materials and Methods

This study characterizes the stainless steel life cycle through material flow analysis by following the methodology originated by the Yale Stocks and Flows project (e.g. ref 7). The life cycle, illustrated through a circular display (19) in Figure 1, has four main processes: production, manufacturing, use, and recycling and waste management. Processes are interconnected through markets, enabling at every life stage the transparent accounting of production, trade, stock changes, and consumption. The scrap market closes the cycle by connecting different life stages through the generation and use of scrap.

Production. In a process called “crude production”, most stainless steels are produced in an electric arc furnace that is charged with primary and secondary raw materials (24). Primary input materials include ferrochromium, often ferromanganese, and sometimes ferromolybdenum and other specialty metals; secondary metals include scrap of stainless steels, alloy steels, and carbon steels. The molten stainless steel is either continuously cast or cast into a semifinished form (“semis”) before the subsequent hot- and cold-rolling steps. The resulting semifinished and finished stainless steel products can, in a broad sense, be distinguished by shape into “flat” and “long” products (Figure 2, for details see Supporting Information, II, III).

Manufacturing. In manufacturing, semifinished and finished stainless steels are used to make products for five

* Corresponding author e-mail: barbara.reck@yale.edu.

[†] Yale University.

[‡] National Institute for Environmental Studies.

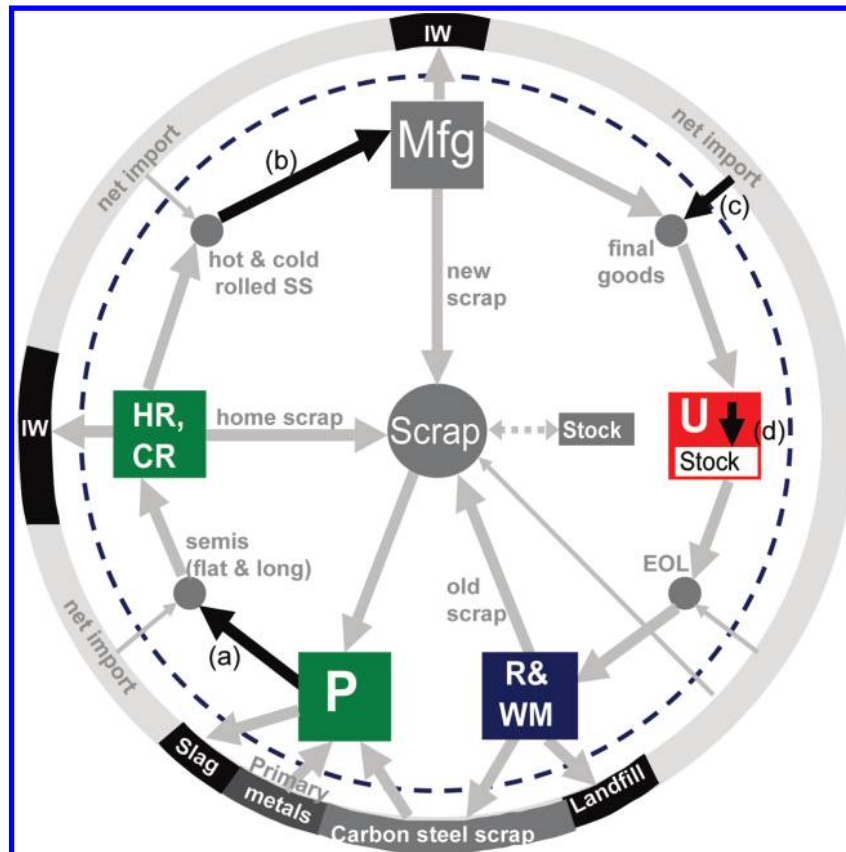

FIGURE 1. Generic anthropogenic stainless steel cycle, with the main processes of crude stainless steel production (P), stainless steel making including hot and cold rolling (HR, CR), manufacturing (Mfg), use (U), and recycling and waste management (R&WM). The processes are connected through markets, each related to other regions through net import flows. Flows highlighted in black are further analyzed in Figure 4: (a) crude production, (b) use in manufacturing, (c) net import of final goods, (d) net addition to in-use stocks. Scrap stock changes (generally modest) are shown by a dashed line. "Carbon steel scrap" stands for "carbon and alloy steel markets", EOL stands for end-of-life, and IW stands for industrial wastes. More details are provided in the Supporting Information, I.

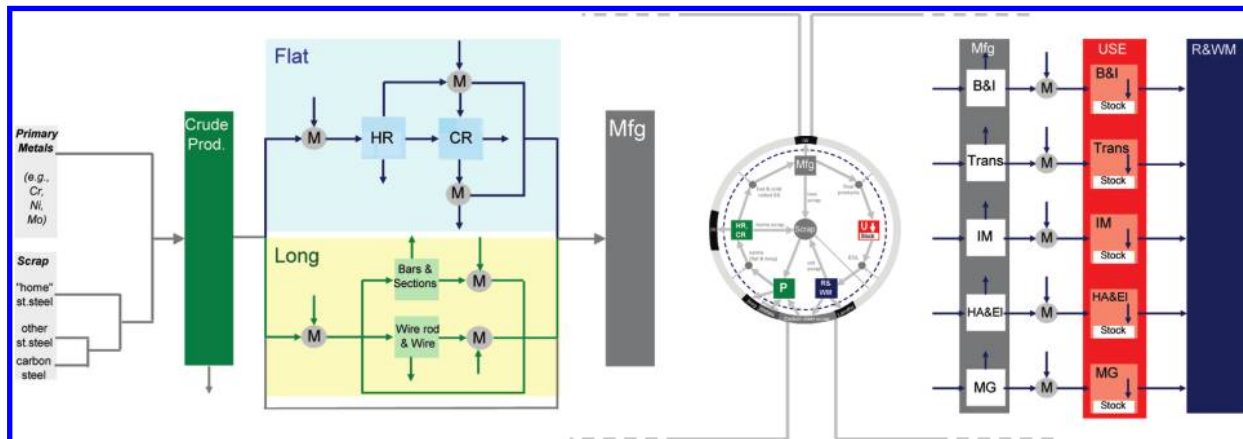

FIGURE 2. Generic stainless steel market with detailed flowcharts for stainless steel making (left) and end use sectors (right). Crude prod.: stainless steel crude production; flat: flat stainless steel products (e.g., sheets, plates, strips); long: long stainless steel products (e.g., seamless tubes, wires); HR: hot rolling; CR: cold rolling; B&I: building and infrastructure; Trans: transportation; IM: industrial machinery; HA&E: household appliances and electronics; MG: metal goods.

end use sectors (building and infrastructure, transportation, industrial machinery, household appliances and electronics, and metal goods [e.g., fasteners, kitchen articles, medical instruments]; Figure 2). Manufactured final goods are often traded before being used. To quantify the trade of final goods, (i) the most relevant commodities for stainless steel were identified, a total of 64, and their trade data were collected (26); (ii) their stainless steel content was estimated (see Table

S3, Supporting Information), and (iii) the stainless steel content in traded final goods was calculated by combining mass data with metal concentrations.

Use. The flow of stainless steel into use was calculated by adding the net import of final goods to the outflow from manufacturing. This was done separately for the five end use sectors discussed earlier. Final goods remain in use until their lifetime expires, with lifetimes varying from a few years

TABLE 1. Estimates Required for the Calculation of End-of-Life Flows (27), and Related Results^a

| End Use Sector | Results | | average lifetime (in years) | coefficient of variation | to landfill | Estimates | | | |
|------------------------------------|--------------------------------|-------------|-----------------------------|--------------------------|-------------|-------------------------|---|-----------------|-----|
| | Flow into Use (global average) | | | | | collected for recycling | | | |
| | 2000 | 2005 | | | | total | as stainless steel | as carbon steel | |
| Building & Infrastructure | 17% | 18% | 50 | 30% | 8% | 92% | 95% | 5% | |
| Transportation (total) | 21% | 18% | | | 13% | 87% | 85% | 15% | |
| <i>Transp. (pass. cars)</i> | 17% | 14% | 14 | 15% | | | | | |
| <i>Transp. (others)</i> | 4% | 4% | 30 | 20% | | | | | |
| Industrial Machinery | 29% | 26% | 25 | 20% | 8% | 92% | 95% | 5% | |
| Household Appliances & Electronics | 10% | 10% | 15 | 20% | 30% | 70% | 95% | 5% | |
| Metal Goods | 23% | 27% | 15 | 25% | 40% | 60% | 80% | 20% | |
| Results | 2000 | 2005 | | | | | EOL Recycling Rate specific downcycled | | |
| | | | | | | 22% | 78% | 66% | 12% |
| | | | | | | 21% | 79% | 70% | 9% |

^a Average end use sector lifetimes with coefficients of variation; the share of end-of-life flows that are landfilled as opposed to collected for recycling, with the latter being divided into metal-specific and metal-unspecific recycling. All estimates are global averages for the early 2000s and based on expert interviews. Results are provided for sector-specific information on flows into use (global average is the result of individual country information), on landfilling rates, and on end-of-life (EOL) recycling rates in 2000 and 2005.

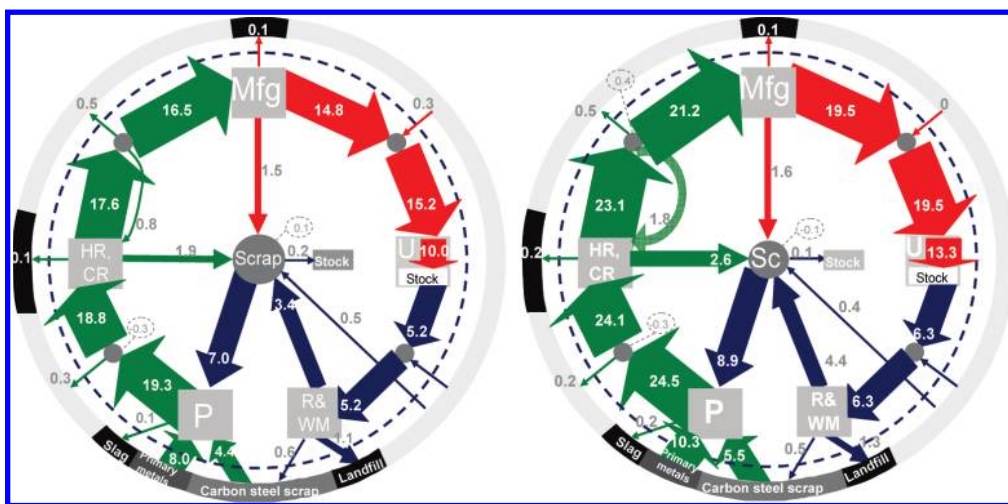

FIGURE 3. Global anthropogenic stainless steel cycle in 2000 (left) and 2005 (right). Green flows relate to the production of stainless steel, orange flows to their end use (production and use of final goods), and blue flows to their end-of-life (generation and management of end-of-life products). The units are teragrams of stainless steel per year.

in the case of electronics to as much as a century in buildings (Table 1). The net addition to in-use stocks is determined for each sector by the difference between the flows into and out of use.

Recycling and Waste Management. The end-of-life flow was calculated with a product residence time model for the five end use sectors (8), assuming a normal distribution. Table 1 summarizes for each sector the estimated lifetimes, coefficients of variation, and the share of end-of-life metal collected for recycling as opposed to landfilled (27). The collected stainless steel is divided into a larger fraction that is recycled as stainless steel and a smaller fraction that is lost to the carbon- and alloy steel-scrap markets due to insufficient separation. Data management and uncertainties are discussed in the Supporting Information (including the global stainless steel cycles for 2000 and 2005 before and after data reconciliation (28)).

3. Results

This study offers a detailed characterization of the anthropogenic stainless steel life cycle. For the years 2000 and 2005, it quantifies the stainless steel cycle at three spatial levels:

world, 8 regions, and 51 countries, country groups, and territories (summarized as “countries” hereafter).

World Level. The global cycle for the year 2000 is shown on the left side of Figure 3. In that year, nearly 20 teragrams (Tg) of stainless steel were initially produced, of which nearly 15 Tg entered into use. Two-thirds of the latter amount constituted in-use stock. Stainless steel scrap was effectively recovered from manufacturing stages and after discard, so that only 41% of the stainless steel produced was from virgin stock.

The 2005 global cycle appears on the right side of Figure 3; it is greatly changed from that of 5 years earlier. Stainless steel crude production rose by 27% over this time period, and the use of stainless steel in manufacturing and its end use grew by 32% (the higher growth rate is explained by a higher efficiency in manufacturing in 2005; see Supporting Information, III.3). The growth in the net addition to in-use stocks, 38%, was even higher. Of the flow entering waste management, about 21% was lost to landfilling and about 9% by incorporation into carbon steel scrap.

Country Level, Production. All country and regional cycles for 2000 and 2005 are provided in the Supporting

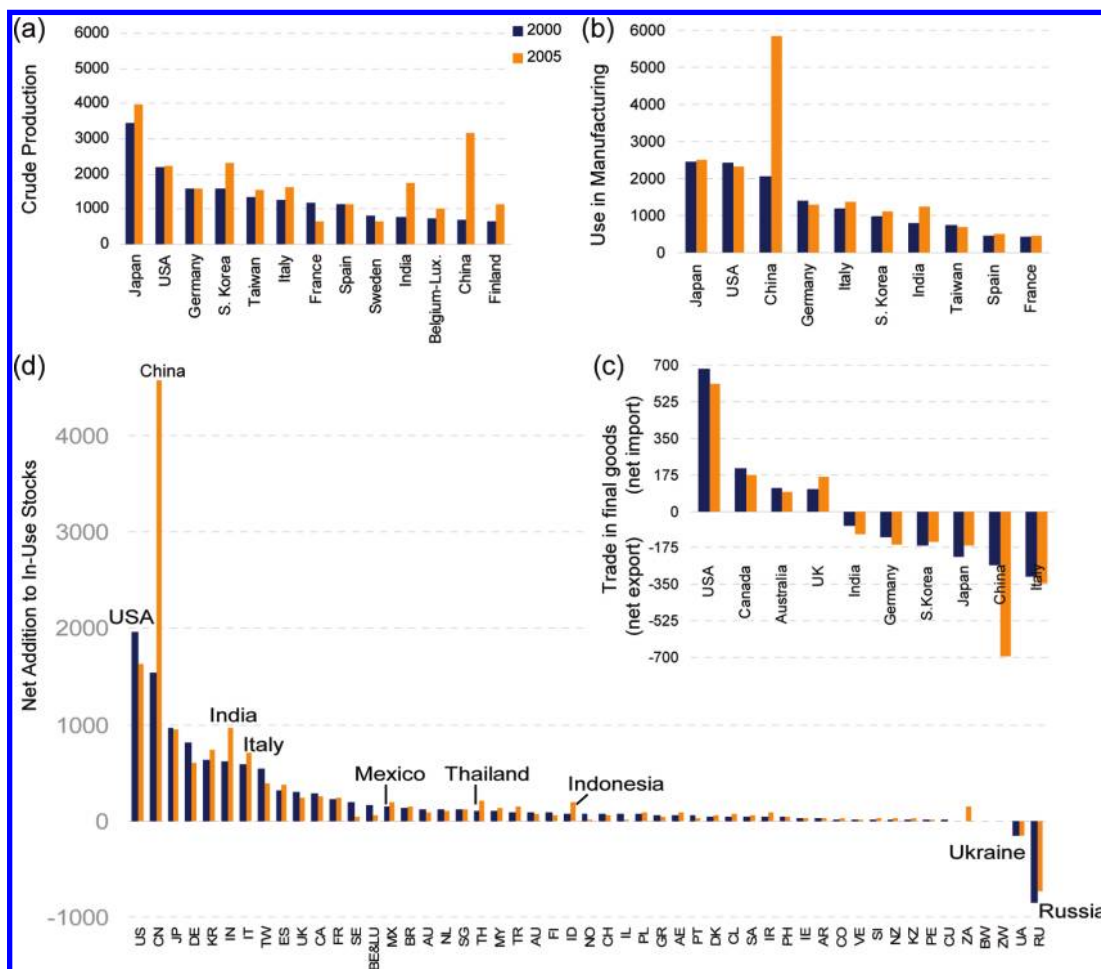

FIGURE 4. Principal stainless steel flows for countries with the largest flows in 2000 (left bars), compared to those in 2005 (right bars): (a) crude production, (b) stainless steel use in manufacturing, (c) net import of final goods, (d) net addition to in-use stocks for all 51 countries, country groups, and territories (for comments on the results for Russia and Ukraine see Supporting Information, IV.2; country codes on x-axis as defined by ISO 3166-1-alpha2 (35)). The units are gigagrams of stainless steel per year.

Information. Here, we extract particularly interesting information from those cycles, beginning with that for production (Figure 4a). Almost half of the world's crude production growth between 2000 and 2005 took place in China (47%). Other Asian countries that increased their production substantially were India (18% of global growth), South Korea (14%), and Japan (10%). Together, Asian countries accounted for 93% of the world's growth in stainless steel production. Europe saw a growth in production only in Finland, Italy, and Belgium while production in France and Sweden decreased during the early 2000s.

Manufacturing. By 2005, China dominated the use of stainless steel in manufacturing by almost a factor of 2 (5840 gigagram [Gg] as opposed to Japan's 2510 Gg; Figure 4b). This was made possible by China's quadrupled crude production and a doubling of its imported semifinished and finished stainless steel products. The situation was different for India, the other new player, who was a net exporter of these products. Other important users in manufacturing include Japan, USA, Italy, and Germany.

Trade of Final Goods. By 2005, China had become the world's largest net exporter of final goods (700 Gg), doubling the next largest (Italy; Figure 4c). Yet, Chinese exports accounted for only 13% of its manufacturing output, indicating that China manufactured most of its final goods for its domestic market (see also Figure 5). The USA is by far the largest net importer of stainless steel-containing final goods, mostly in the form of kitchen articles, other metal goods, and passenger cars (exhaust systems).

End Use, Net Addition to Stock. In 2000, the end use of stainless steel was dominated by the USA, followed by Japan, China, and Germany. The situation was very different in 2005, when China used 70% more stainless steel (4670 Gg) than the USA (2740 Gg). The third largest user, Japan, used about 2000 Gg in both years.

China similarly dominated the net addition to stocks in 2005 (Figure 4d, in which we show results for our entire set of countries). Most of China's accumulated stainless steel went into industrial machinery (1360 Gg or 30%), followed by buildings and infrastructure (1180 Gg, 26%), metal goods (1030 Gg), household appliances and electronics (510 Gg), and transportation (480 Gg; see the detailed diagram in the Supporting Information, Figure S5). Countries such as the USA, Germany, Taiwan, and the United Kingdom added less to its in-use stocks in 2005 than 5 years earlier, while India, South Korea, and Italy increased their net additions. Like China, the latter three had also increased their crude production over the 5-year period while the others saw both a decline in their stainless steel production and their in-use-stock additions.

China is unusual in that, both in 2000 and 2005, almost 100% of its flow "into use" remained in the economy as "net addition to in-use stocks". The reason is an extremely small end-of-life flow that can be explained by China having used hardly any stainless steel a product lifetime ago. The contrary is true for industrialized countries that have used stainless steel over several decades, where new stainless steel products mostly replace older ones, resulting in much lower rates of

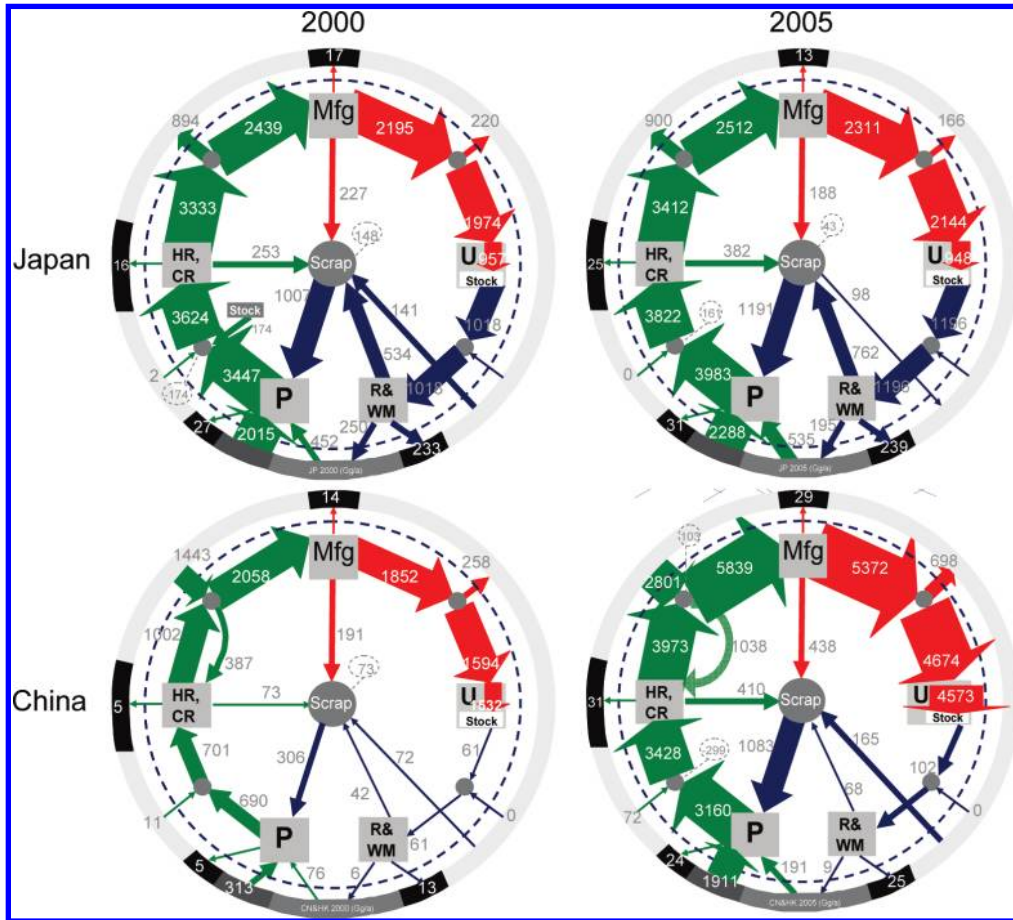

FIGURE 5. Stainless steel diagrams for China and Japan in 2000 and 2005. The units are gigagrams of stainless steel per year.

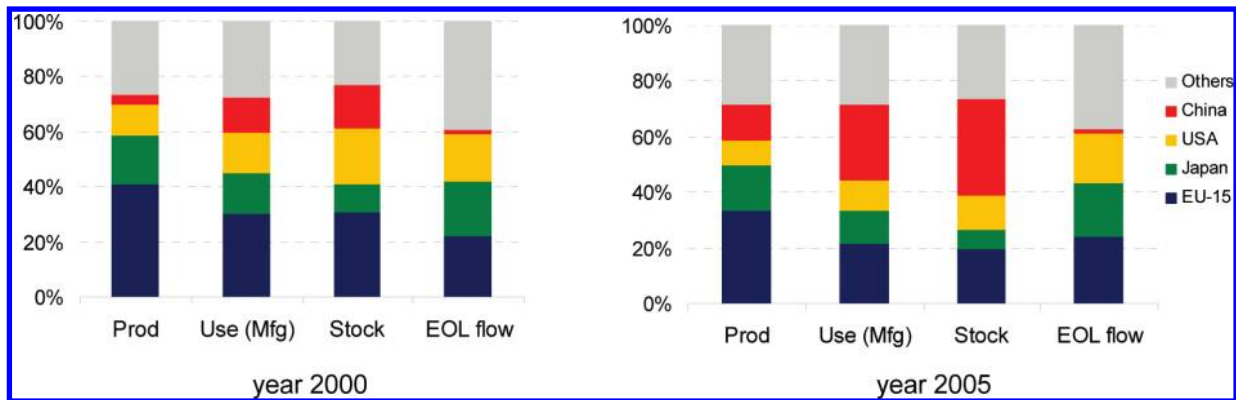

FIGURE 6. Global market share of five countries or regions (EU-15, Japan, USA, China, others) for four major flows (stainless steel crude production, use of stainless steel in manufacturing, net addition to in-use stocks, end-of-life flows).

net addition to stocks (ranging between, in 2005, 45% in Japan and 60% in USA and Germany). China will start generating major end-of-life flows between 2015 and 2020: with about 40% of the new stainless steel stock in 2005 having an average lifetime of just 15 years, those products will be discarded within the next decade, followed soon by the first replaced machinery and infrastructure equipment.

Dramatic Reversal of China and Japan. A particularly fascinating result of this study relates to Japan, traditionally the largest stainless steel producer, and China, historically a much smaller player. We compare the cycles for the two countries for 2000 and 2005 in Figure 5. Between 2000 and 2005, China's growth rates were 360% in production, 180% in manufacturing, 190% in use, and 66% at end-of-life. In turn, Japan only saw a 16% increase in production, a 3% growth in manufacturing, 9% increase in use, and 18% growth

at end-of-life (higher end-of-life growth rates reflect higher growth rates a product lifetime ago). It is noteworthy that, in 2005, China used more than twice as much stainless steel in manufacturing and end-use than Japan, but only discarded a tenth of Japan's end-of-life flow. As a result, China accumulated more than four times as much stainless steel to its in-use stocks than Japan.

Stainless Steel Dynamics in the Major World Regions.

To understand the global impact of China's strong growth, we look in Figure 6 at the market shares of major world regions in 2000 and 2005. For both years, we compare China's share of the world market with those of Japan, the EU-15, the USA, and all others for "crude production", "use in manufacturing", "net addition to in-use stocks", and "end-of-life flows". In 2000, the industrialized regions in Japan, EU-15, and the USA constituted 60% of the world market across the stainless

steel life cycle and nearly 70% in crude production. By 2005, these market shares decreased to 50% in production, 45% in manufacturing, and less than 40% in net-addition-to-stocks. At end-of-life, however, they still covered more than 60% of the global flows as China started using stainless steel only recently. By 2005, China alone accounted for 35% of the global net-addition-to-stocks and 27% of all stainless steel used in manufacturing.

4. Discussion

This is the first study characterizing the global life cycle of stainless steel. Covering the beginning of the 21st century, it illustrates the beginning of a major shift in the dynamics of the global stainless steel market that saw China evolve as its dominant player. In 2000, as in the previous two decades, the global stainless steel market was dominated by Japan, the USA, the EU-15, South Korea, and Taiwan while China played a relatively modest role. This situation changed entirely by 2005 when China dominated by a factor two or more the use of stainless steel in manufacturing, end use, and net addition to in-use stocks. It is a trend that continues, with China's supply and demand of stainless steel products growing quickly, demonstrated by a crude production of 6940 Gg in 2008 and almost 9000 Gg in 2009 (as opposed to 3160 Gg in 2005; ref 24).

China's increased self-reliance of crude and finished stainless steel has consequences for traditional stainless steel exporters (e.g., Japan) who will see their main export market of the past decade collapse. On the demand side, China's need for stainless steel-containing final goods will likely continue to grow. Despite almost having tripled its end use between 2000 and 2005, China's per capita use of stainless steel was still low (3.6 kg per capita in 2005) when compared to the world average (4.2 kg per capita) or to industrialized countries (typically between 7 and 15 kg per capita).

Growth rates similar to those for stainless steel have also been reported for other metals used in China. Closely related to stainless steel are chromium and nickel, whose use in China rose by factors of 3–5 between 2000 and 2005, met to a large extent by imports (18, 19, 29, 30). China became a major importer of many other primary raw materials, a major user of most industrial metals, and the world's largest exporter of metals in manufactured final goods (31). Our results for stainless steel were mirrored by those for iron (31) and aluminum (12, 13) and were less pronounced for copper, where products typically have a shorter lifetime (31).

The present study of a metal alloy highlights an interesting difference when compared to elemental cycles. The latter typically see a set of countries dominating metal production (influenced by the geological availability of the raw materials) different from those dominating the fabrication, manufacture, and use of final goods (e.g. ref 19). In contrast, alloys such as stainless steels are produced, manufactured, and used by a relatively uniform set of countries (Figure 4). (Note that the related imports of chromium and nickel lie outside of the system boundary.)

The stainless steel-specific end-of-life recycling rates of 70% in 2005 and 66% in 2000 (Table 1) are consistent with findings from Japan (20, 22, 32). Small fluctuations over time reflect changes in how stainless steel is used in the five end use sectors and, depending on the respective lifetimes, when it will become available for recycling (see Table 1, and the example for China in the Supporting Information, Figure S5). The stainless steel end-of-life recycling rates are high when compared to other metals (mostly below 50% (33)). This can be explained by the high price of nickel (20, 32), one of stainless steel's main alloying elements. For comparison, recycling rates of nickel (57% (19)) and chromium (54% (18)) are also relatively high.

The only metal recycled more efficiently at its end-of-life than stainless steel is iron (76% (17)). Iron is used predominantly in buildings and infrastructure, a sector with a well-established recycling chain. More importantly, iron is not downcycled to other metal fractions, while some stainless steel is "downcycled" into carbon or alloy steels (9% in 2005 and 12% in 2000; Table 1). When this happens, that stainless steel becomes unavailable for future metal-specific recycling. Its valuable constituents chromium and nickel become impurities and lose their potential to reduce the demand for energy-intensive primary raw materials in stainless steel making (3).

Information on future end-of-life flows can be derived by analyzing the type of end-use sectors in which stainless steel stocks accumulated and their respective lifetimes (34). In particular in China, both in 2000 and 2005, about a quarter of stainless steel went into long-term use in buildings and infrastructure, while three-quarters was used in applications with much shorter lifetimes. This is in stark contrast to carbon steel where, in 2004, about half of all metal was accumulated in buildings and infrastructure (31). Secondary stainless steel will, therefore, be available in significant amounts much earlier than carbon steel, starting between about 2015 and 2020. This gives the Chinese waste management industry only some 5–10 years to prepare for the recovery and reuse of a large stainless steel discard flow.

Acknowledgments

This research was funded by the International Stainless Steel Forum, the Nickel Institute, the International Chromium Development Association, and the International Molybdenum Association. We thank Peter Kaumanns, Staffan Malm, and Pascal Payet-Gaspard from the International Stainless Steel Forum and Fritz Teroerde from the International Chromium Development Association for providing data and for helpful discussions and Susanne Rotter and three anonymous reviewers for valuable comments on this paper.

Supporting Information Available

A detailed description of the stainless steel making process, trade codes for 93 commodities, uncertainties; end-use-sector specific results in manufacturing, end use, and at end-of-life; stainless steel cycles at country (51), regional (8), and global level for years 2000 and 2005 (120 cycles in total; global cycles before and after data reconciliation). This material is available free of charge via the Internet at <http://pubs.acs.org>.

Literature Cited

- Johnson, J.; Harper, E. M.; Lifset, R.; Graedel, T. E. Dining at the periodic table: Metals concentrations as they relate to recycling. *Environ. Sci. Technol.* **2007**, *41* (5), 1759–1765.
- Müller, D. B.; Wang, T.; Duval, B.; Graedel, T. E. Exploring the engine of anthropogenic iron cycles. *Proc. Natl. Acad. Sci. U.S.A.* **2006**, *103* (44), 16111–16116.
- Eckelman, M. J. Facility-level energy and greenhouse gas life-cycle assessment of the global nickel industry. *Resour. Conserv. Recycl.* **2010**, *54* (4), 256–266.
- Chapman, P. F.; Roberts, F. *Metal Resources and Energy*; Butterworth and Co. Ltd: Borough Green, Sevenoaks, Kent TN16 8PH, England, 1983.
- Norgate, T. E.; Lovel, R. R. *Water Use in Metal Production: A Life Cycle Perspective*; CSIRO: Australia: 2004.
- Johnson, J.; Reck, B. K.; Wang, T.; Graedel, T. E. The energy benefit of stainless steel recycling. *Energy Policy* **2008**, *36* (1), 181–192.
- Graedel, T. E.; Van Beers, D.; Bertram, M.; Fuse, K.; Gordon, R. B.; Gritsinin, A.; Kapur, A.; Klee, R. J.; Lifset, R. J.; Memon, L.; Rechberger, H.; Spatari, S.; Vexler, D. Multilevel cycle of anthropogenic copper. *Environ. Sci. Technol.* **2004**, *38* (4), 1242–1252.
- Spatari, S.; Bertram, M.; Gordon, R. B.; Henderson, K.; Graedel, T. E. Twentieth century copper stocks and flows in North

- America: A dynamic analysis. *Ecol. Economics* **2005**, *54* (1), 37–51.
- (9) Daigo, I.; Hashimoto, S.; Matsuno, Y.; Adachi, Y. Material stocks and flows accounting for copper and copper-based alloys in Japan. *Resour. Conserv. Recycl.* **2009**, *53* (4), 208–217.
 - (10) Graedel, T. E.; Beers, D. v.; Bertram, M.; Fuse, K.; Gordon, R. B.; Gritsinin, A.; Harper, E. M.; Kapur, A.; Klee, R. J.; Lifset, R.; Memon, L.; Spataro, S. The multilevel cycle of anthropogenic zinc. *J. Ind. Ecol.* **2005**, *9* (3), 67–90.
 - (11) Nakajima, K.; Matsubae-Yokoyama, K.; Nakamura, S.; Itoh, S.; Nagasaka, T. Substance flow analysis of zinc associated with iron and steel cycle in Japan, and environmental assessment of EAF Dust Recycling Process. *ISIJ Int.* **2008**, *48* (10), 1478–1483.
 - (12) Hatayama, H.; Daigo, I.; Matsuno, Y.; Adachi, Y. Assessment of the recycling potential of aluminum in Japan, the United States, Europe and China. *Mater. Trans.* **2009**, *50* (3), 650–656.
 - (13) Chen, W.; Shi, L.; Yi, Q. Substance flow analysis of aluminium in mainland China for 2001, 2004 and 2007: Exploring its initial source, eventual sink and the pathways linking them. *Resour. Conserv. Recycl.* **2009** (DOI: 10.1016/j.resconrec.2009.10.013).
 - (14) Harper, E. M.; Graedel, T. E. Illuminating tungsten's life cycle in the United States: 1975–2000. *Environ. Sci. Technol.* **2008**, *42* (10), 3835–3842.
 - (15) Kwonpongsagoon, S.; Waite, D. T.; Moore, S. J.; Brunner, P. H. A substance flow analysis in the southern hemisphere: cadmium in the Australian economy. *Clean Technol. Environ. Policy* **2007**, *9* (3), 175–187.
 - (16) Geyer, R.; Davis, J.; Ley, J.; He, J.; Clift, R.; Kwan, A.; Sansom, A.; Jackson, T. Time-dependent material flow analysis of iron and steel in the UK Part I: Production and consumption trends 1970–2000. *Resour. Conserv. Recycl.* **2007**, *51* (1), 101–117.
 - (17) Wang, T.; Müller, D. B.; Graedel, T. E. Forging the anthropogenic iron cycle. *Environ. Sci. Technol.* **2007**, *41* (14), 5120–5129.
 - (18) Johnson, J.; Schewel, L.; Graedel, T. E. The contemporary anthropogenic chromium cycle. *Environ. Sci. Technol.* **2006**, *40* (22), 7060–7069.
 - (19) Reck, B. K.; Müller, D. B.; Rostkowski, K.; Graedel, T. E. Anthropogenic nickel cycle: Insights into use, trade, and recycling. *Environ. Sci. Technol.* **2008**, *42* (9), 3394–3400.
 - (20) Igarashi, Y.; Daigo, I.; Matsuno, Y.; Adachi, Y. Dynamic material flow analysis for stainless steels in Japan reductions potential of CO₂ emissions by promoting closed loop recycling of stainless steels. *ISIJ Int.* **2007**, *47* (5), 758–763.
 - (21) Daigo, I.; Matsuno, Y.; Adachi, Y. Substance flow analysis of chromium and nickel in the material flow of stainless steel in Japan. *Resour. Conserv. Recycl.* **2010** (DOI: 10.1016/j.resconrec.2010.01.004).
 - (22) Hashimoto, S.; Daigo, I.; Eckelman, M.; Reck, B. K. Measuring the status of stainless steel use in the Japanese socio-economic system. *Resour. Conserv. Recycl.* **2010** (DOI: 10.1016/j.resconrec.2009.12.003).
 - (23) Lo, K. H.; Shek, C. H.; Lai, J. K. L. Recent developments in stainless steels. *Mater. Sci. Eng. R: Rep.* **2009**, *65* (4–6), 39–104.
 - (24) Cunat, P.-J. *The Euro Inox handbook of stainless steel*; Euro Inox: Luxembourg, 2002.
 - (25) ISSF International Stainless Steel Forum; www.worldstainless.org (last accessed 11/2009).
 - (26) UN Comtrade database, United Nations Statistics Division; http://comtrade.un.org/db/ (last accessed 06/2009).
 - (27) Malm, S.; Kaumanns, P.; Teroerde, F. Personal Communication (Workshop with Team Stainless/International Stainless Steel Forum). In Düsseldorf, Germany, 2009.
 - (28) Cencic, O.; Rechberger, H. Material flow analysis with software STAN. *J. Environ. Eng. Manage.* **2008**, *18* (1), 3–7.
 - (29) Papp, J. F. *2005 minerals Yearbook, Chromium*; US Geological Survey: Reston, VA, 2007.
 - (30) *INSG World Nickel Statistics*; International Nickel Study Group: Lisbon, Portugal, 2006.
 - (31) Wang, T.; Mao, J.; Johnson, J.; Reck, B. K.; Graedel, T. E. Anthropogenic metal cycles in China. *J. Mater. Cycles Waste Manage.* **2008**, *10* (2), 188–197.
 - (32) Daigo, I.; Matsumoto, Y.; Matsuno, Y.; Adachi, Y. Material stock and flow analysis of stainless steel based on mass balances of Cr and Ni. *Tetsu-to-Hagané* **2009**, *95* (6), 54–62, in Japanese.
 - (33) Graedel, T. E.; Allwood, J.; Birat, J.-P.; Buchert, M.; Hagelüken, C.; Meskers, C. E. M.; Reck, B. K.; Sibley, S. F.; Sonnemann, G. The recycling of metals: A status report. *J. Ind. Ecol.* **2010**, in review.
 - (34) Kleijn, R.; Huele, R.; van der Voet, E. Dynamic substance flow analysis: the delaying mechanism of stocks, with the case of PVC in Sweden. *Ecol. Economics* **2000**, *32* (2), 241–254.
 - (35) (ISO), I. O. f. S. English country names and code elements; http://www.iso.org/iso/country_codes/iso_3166_code_lists/english_country_names_and_code_elements.htm#t (last accessed 11/2009).

ES903584Q