

Louvre Abu Dhabi: A rain of light

In the Louvre Abu Dhabi, stainless steel not only protects precious artwork, but becomes art itself. The museum's breathtaking roof contains molybdenum to withstand one of the world's most corrosive environments. Inside, rays of sunlight dance across surfaces, creating a spectacle unlike any other.

Where the desert meets the sea in Abu Dhabi, United Arab Emirates, a massive dome of stainless steel and aluminum 'stars' seems to levitate above water. But award-winning architect Jean Nouvel's design is no desert mirage. The stainless steel capped structure contains the new Louvre Abu Dhabi, a 'museum city' of 55 individual buildings, housing priceless artwork. Its design is a work of art itself, as brilliant as the pieces it houses. This extravagant new construction is part of the Emirate's wider initiative to diversify its economy by welcoming visitors as an international, cultural destination. The museum's many stainless steel features, therefore, help to guarantee the longevity of the complex as a world-class tourist destination.

As it seldom rains in the Arabian desert, the dome did not need to be fully closed.

Like an upended, woven basket, sunlight filters in through select points, creating a one-of-a-kind spectacle known as the 'rain of light'. The woven design harkens back to the interlacing of woven palm fronds traditionally used on Emirati roofs as protection from the sun. Throughout the day, scattered fragments of light float according to the course of the sun like levitating diamonds. This dramatic effect is inspired by the semi-covered streets of a special kind of Arab market, known as a souk. Cut out against the enviroing darkness, one can almost grasp the sun's rays as they mingle with minute particles of dust in motionless suspension.

A nebula of metal stars

Sunlight enters the dome through a 'nebula of stars' weighing over 7,500 tonnes – as much as the Eiffel Tower. The

roof is composed of 7,850 star-shaped elements superimposed over eight layers. The stainless steel clad outer layers are separated from the aluminum inner layers by a five-meter high standalone steel structure. In total, the layers contain nearly 460,000 geometrically distinct intersections, linked by over 410,000 connection points. In addition to their differing shapes, the stars' angular arrangement varies from one layer to the next, which complicates the passage of light.

The steel structure separating the layers is made of 85 monumental elements, or *Super-Sized Elements (SSE)*. The SSE are subdivided into 11 unique modules, each weighing on average 50 tonnes. They are welded or fastened by bolted plates. These SSE were coated with paint that reflects the infrared energy of sunlight, contributing to lower temperatures inside the structure and also to enhanced color vibrancy.

With a simple shape – a square surrounded by four triangles – the stars produce intricate arrangements similar to those found in traditional Arab art and architecture. The result is both visual complexity and excellent passive insulation for all the museum's facilities. By day, the dome blocks 98.9% of the sun's light, which helps maintain a stable temperature for both the art collection and visitors. The remaining sunlight dances in a continuously moving spectacle. At night, the process reverses as 4,500 projectors cast light out of the dome in fragmented beams, transforming the museum into an imposing, seemingly moonlit crystal, visible far beyond the Abu Dhabi shoreline. ➤

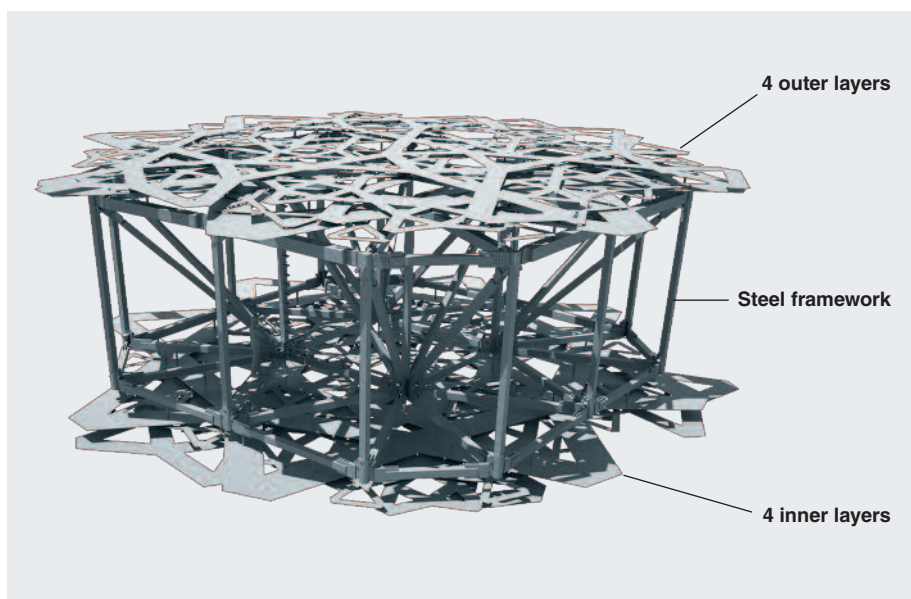

Four outer layers made of aluminum and stainless steel, and four inner layers made of aluminum, separated by a five-metre high standalone steel structure. © Jean Nouvel Architecte and © Waagner Biro Stahlbau AG



The roof filters the stark Middle Eastern sunlight and creates a mysterious atmosphere with constantly changing lighting conditions. Germination by Giuseppe Penone © Photography Roland Halbe – Louvre Abu Dhabi – Architect Jean Nouvel

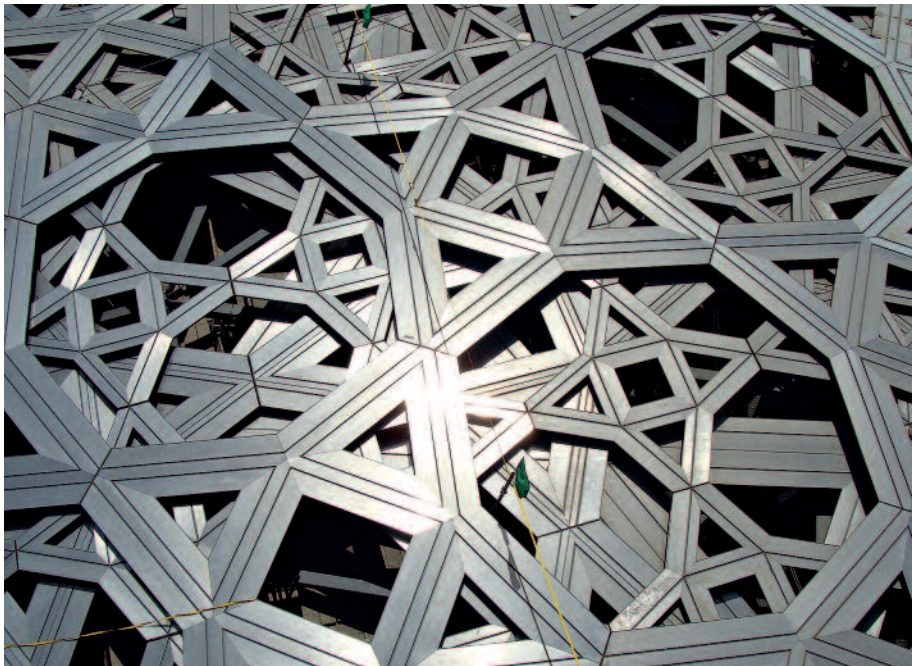

The dome's intricate pattern of "stars" is clearly visible from above. © Waagner Biro Stahlbau AG

The engineers and the architect used stainless steel for the four upper layers of the dome, which are the most exposed to the climate, but also the most visible. The 4,481 stars of the upper layers were all clad on their upper face with 0.8-mm thick sheets made of duplex stainless steel. These sheets were first welded to each other, then fastened to the aluminum substructure through neoprene-insulated joints to avoid any galvanic corrosion of the aluminum by the stainless steel. To completely separate the two metals, the underside of the stainless steel sheets are clad with an anti-corrosion protective polyethylene film. The cladding takes on the exact curvature of the surface of the stars; an angle of slightly less than 180°, allowing for the low height of the dome of 36 meters and its wide diameter of 180 meters, accentuating its lightweight effect. >

A study of the sun

Designing the roof of the Louvre Abu Dhabi was no small feat. Engineers analyzed the course of the sun across the site over 365 consecutive days and used cutting edge information technology as well as the most recent BIM (Building Information Modelling) applications to calculate the ideal arrangement of the dome's stars. In order to test the light's path in real conditions, they built a mock-up on a scale of 1/200 of the intended size, followed by a life-sized model, representing a six-meter diameter subsection of the dome. In total, the design and construction of the dome took over five years.

Stainless steel for durability and aesthetics

In addition to its complex geometry, the dome's materials play a decisive role in the 'rain of light'. Extruded aluminum was used as the substructure of the eight layers of stars for its ease in terms of manufacturing, implementation, weight and corrosion resistance, but also for its light reflecting capabilities.

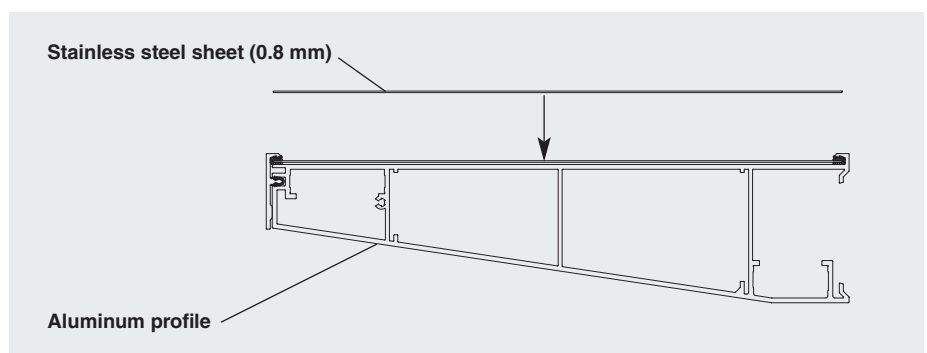

Cladding of an aluminum profile. © Waagner Biro Stahlbau AG

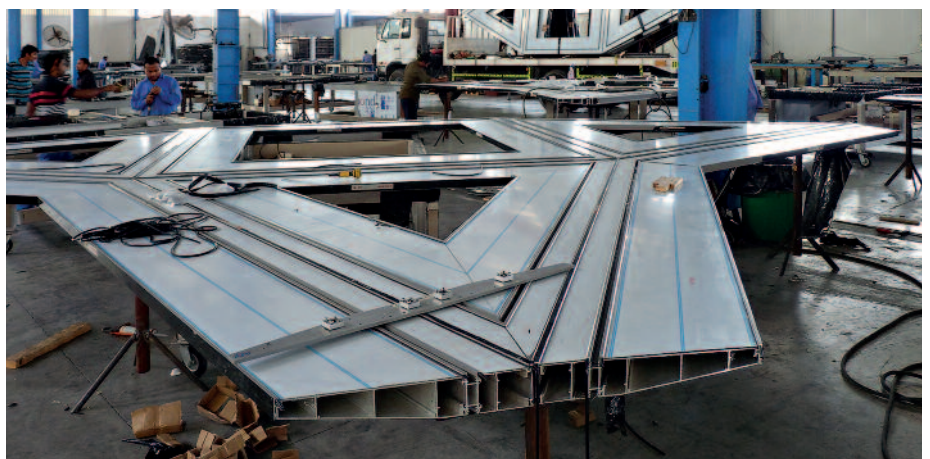

Cladding of one of the aluminum stars with molybdenum-containing stainless steel in an Abu Dhabi plant. 500,000 profile parts were assembled in two profile machining centers. © elumatec AG

The Louvre Abu Dhabi inhabits one of the most corrosive environments in the world; an island exposed to desert heat and high humidity, surrounded by salty ocean spray. To resist this extreme environment, 3% molybdenum-containing type 2205 duplex stainless steel was used. Thanks to its higher molybdenum content, this stainless steel is significantly more corrosion-resistant than the 2% molybdenum-containing Type 316 austenitic stainless steel that is often used in less aggressive coastal applications. The matte 2E surface finish avoids creating excessive glare that could be blinding in the sun. Additionally, the stainless steel reflects the tints of the changing colours during the course of the day, and contributes to the festival of lights produced by the Louvre. Elsewhere in the museum, grating,

walkways, and meshing are also made of 2205 duplex stainless steel. In all, 300 tonnes of this material have been used in the construction.

Reinforced protection against the sea

Stainless steel rebar was used to reinforce the 4,500 leak tight concrete piles drilled to nearly 15 meters below sea level that support the entire platform of the museum. The same rebar was also used in the 280 submerged columns, the concrete cut-off walls, and in a tailor-made 'protective wall' that safeguards the museum against any threat from the sea such as storms or collisions with ships. The alloy selected for these applications was 2304 duplex stainless steel, with 0.3% molybdenum. Combined

with the ultra-high-performance concrete, this alloy offers both a guarantee against corrosion and a high ductility.

Safe with stainless steel

The admirers of the Louvre Abu Dhabi's valuable collection can rest assured. The pieces will not be impacted by ocean salts or desert sun. Resting on a stainless steel reinforced throne of concrete piles, protected by a stainless steel reinforced moat, and crowned with a stainless steel dome, the artwork and its visitors are safeguarded all around by this amazing material. Light raining in through its roof, the mirage-like Louvre Abu Dhabi is a mystical, yet calculated cultural artefact, one that will stand for many generations to enjoy, thanks to the durability imbued by molybdenum. (TP)



At night, the dome sparkles from the inside. The stainless steel reinforced concrete walls in the foreground protect the museum from the sea.
© Louvre Abu Dhabi – photography Mohamed Somji – Architect Jean Nouvel