

Thames Gateway Water Treatment Works

The first water desalination plant in the UK, the Thames Gateway Water Treatment Works in East London, opens in 2010. It will treat water from the brackish waters of the River Thames, producing up to 150 million litres of clean, fresh, drinking water each day during times of drought or extended periods of low rainfall, or to maintain supplies in the event of an incident at other water treatment facilities. Within the plant, saline river water passes through lamella clarifiers to remove solid particles. The clarifiers are large, open tanks containing a coarse filter media that is supported by a grillage of 78 stainless steel I-beams.

Material Selection

Drinking Water Inspectorate (DWI) approval is needed for all materials that come into contact with drinking water. The main beams were initially specified to be carbon steel with an epoxy coating. However, there was a high risk of damage to the epoxy coating by follow-on operations and maintenance, which would have resulted in rusting and subsequent damage to the £7 million desalination membranes. This concern led to duplex stainless steel grade 1.4462 (S32205) being specified instead. This grade is DWI approved, requires little maintenance and is durable in brackish water without any applied coating (Table 1). The higher material cost of stainless steel is offset against the reduced risk of damage, low maintenance requirements and greater assurance of water quality throughout the plant's design life of at least 60 years.



Figure 1: Desalination plant

Table 1: DWI approved grades of stainless steel in various water types at temperatures encountered in drinking water supply and treatment [1]

Water type	Chloride level (ppm)	Specification
Pure water		1.4301 (S30400)
Supply water	< 350	1.4301 (S30400) ¹⁾
		1.4401 (S31600)
Fresh water or ground water	< 1000	1.4301 (S30400) ¹⁾
		1.4401 (S31600)
		1.4462 (S32205)
		Super austenitic, Super duplex
Brackish water	10,000 – 15,000	1.4462 (S32205) ²⁾
		Super austenitic, Super duplex
Sea water	15,000 – 26,000	Super austenitic, Super duplex

1) Only up to 200 ppm

2) In estuary or tidal waters, 1.4462 is only suitable up to 3,600 ppm



Figure 2: Main beams

Design

Beams

The lamella clarifiers are divided into three cells, which are split in two halves. Each half is supported by 13 stainless steel beams of 17.5 m span, with supporting steel bracing at approximately 3 m intervals. The grid of beams carries a load of 2.5 kN/m² during full working conditions (Figures 3 and 4).

Design of the main beams was completed according to the *Design manual for structural stainless steel* [2] and BS 5950-1 [3]. Guidance in the *Operational guidelines and code of practice for stainless steel products in drinking water supply* was also followed [1].

Directly replicating the carbon steel beam design in duplex stainless steel would have led to a 74 % cost increase. Therefore, a number of measures were undertaken to reduce the cost.

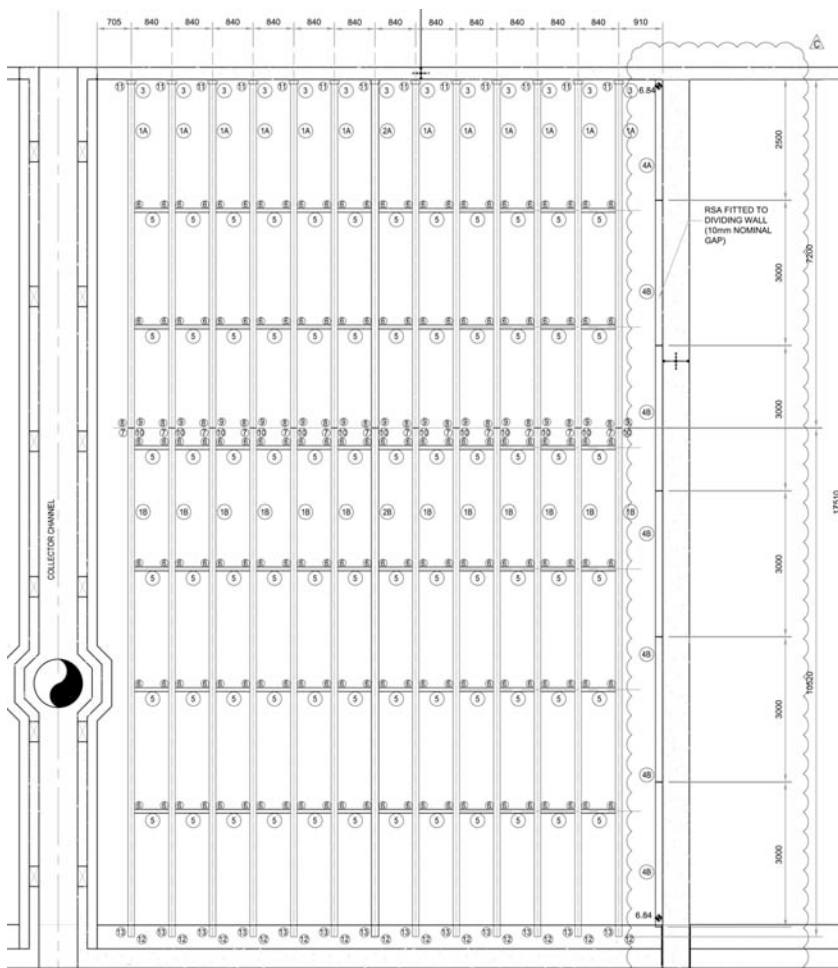

Figure 3: Plan drawing of lamella steelwork



Figure 4: Lamella clarification filter

Cost savings

Design and fabrication:

- The profiles were designed using the superior strength properties of grade 1.4462 (minimum design strength of 460 N/mm²).
- A web depth of 500 mm was selected, to be fabricated from plate material produced in 2 m sheets, hence minimising offcut wastage.
- The flange thicknesses and dimensions were sized to optimise the section modulus.

As a result, the total weight of the stainless steel beams was reduced from 140 tonnes to 75 tonnes, allowing considerable cost savings. The most common profile for the stainless steel beams was a 512 mm x 132 mm I-beam with web thickness of 6 mm and flange thickness of 13 mm.

Transportation:

- As delivery costs from fabrication yard to site were extremely high for the 17.5 m span beams, the sections were designed to include a splice detail to shorten the lengths for delivery. The splices were placed approximately at 1/3 span, creating 2 lengths of beams: 10.52 m and 7.2 m. The beams were connected on site using duplex stainless steel spacers, angles and plate elements. (Figure 6).



Supporting steelwork

The ends of the main beams were supported from the concrete wall using 200 mm x 100 mm x 200 mm cleats connected into 200 mm x 150 mm x 450 mm angle brackets, secured by mechanical anchor fixings (Figure 5). The beams were also braced transversely by 80 mm x 80 mm x 8 mm angles spanning 834 mm in between the beams, at 3 m intervals, to form a grid formation. All the steelwork supporting the main beams was fabricated in duplex stainless steel, hence avoiding any bimetallic corrosion issues.

Fabrication

The steelwork package comprised 78 duplex steel beams with supporting steel; the beams were fabricated from 156 beam sections and spliced together using 624 splice components, 114 angle brackets and 1782 duplex grade bolts, all in grade 1.4462.

The sections were cut, profiled, drilled as necessary and welded with a specified surface finish of 1D in accordance with EN 10088-3 [4]. (This is equivalent to a No. 1 finish to ASTM A480.) All beam and angle sections were formed by laser welding with full 'hybrid fusion welding'. After welding, the surfaces were pickled and passivated to remove any contaminants and produce a standard non aesthetic but corrosion-resistant finish.

Figure 5: Connection of beams to concrete wall

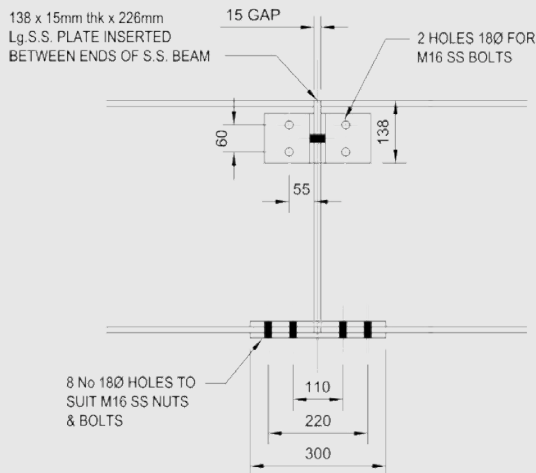

Figure 6: Splice connection



Figure 7: Completed lamella steelwork

Installation

The beams were assembled in pairs and installed using a tower crane (Figure 8). During erection, the stainless steel elements were isolated at all points of contact from carbon steel chains, plates and bolts, to prevent contamination of the surface, which might lead to subsequent corrosion. For this reason, temporary stainless steel bolts were used during erection. However, whenever surfaces are under load and in relative motion, galling may result from local adhesion and rupture of the surfaces; in some cases, weld bonding or seizure may result. Galling problems with stainless steel bolts can be avoided by using dissimilar grades of stainless steel for the bolt-nut combination, by the use of anti-galling agents or by applying a hard surface coating to the bolt or nut.



Figure 8: Installation of a pair of main beams

Information for this case study was kindly provided by Interserve.

References and Bibliography

- [1] DWI Operational Guidelines and Code of Practice for Stainless Steel Products in Drinking Water Supply, 2002, BSSA
- [2] Design manual for structural stainless steel (third edition), Building Series, Volume 3, Euro Inox and SCI, 2006
- [3] BS 5950-1: 2000 Structural use of steelwork in building. Code of practice for design. Rolled and welded sections
- [4] EN 10088-3: 2005 Stainless steels. Technical delivery conditions for semi-finished products, bars, rods, wire, sections and bright products of corrosion resisting steels for general purposes

Online Information Centre for Stainless Steel in Construction:
www.stainlessconstruction.com

Procurement Details

Client:	Thames Water Utilities Ltd
Structural Engineer:	Atkins
Main contractor:	Interserve-Acciona (JV)
Fabricator:	Montanstahl and Millstock Stainless
Steelwork contractor:	Interserve

This series of Structural Stainless Steel Case Studies is sponsored by Team Stainless.

