

Law Courts in Antwerp



The new law courts in Antwerp bring together in one building a range of courts that had previously been spread out at different locations around the city. An open competition held in 1998 by the Belgian government to find a design for the new complex was won by the Richard Rogers Partnership, VK Studio and Ove Arup & Partners.

The law courts are located on Bolivarplaats, a public square on the southwestern edge of Antwerp city centre. The development is part of a long-term master plan for regenerating the city's southern suburbs. On one side the building looks down Antwerp's busy main boulevard, Amerikalei, while on the other it borders open green space surrounded by the roads of a motorway interchange. One road passes directly underneath the building in a tunnel leading to the boulevard, thus creating a kind of gateway situation into the city.

The roof landscape on Antwerp's new law courts has been likened to giant sails tilted to the wind.



As part of a major urban regeneration scheme, the new complex creates a link between the city centre and the district to the south.

The link between the boulevard and the park is further emphasised by a large, glazed atrium at the centre of the law courts complex. Converging on this space are the six separate wings of the building, housing the civil, criminal, family, commercial and juvenile courts and the industrial tribunal. In total these courts along with their associated offices, technical facilities and archives, cover 77,000 square metres of floor space.



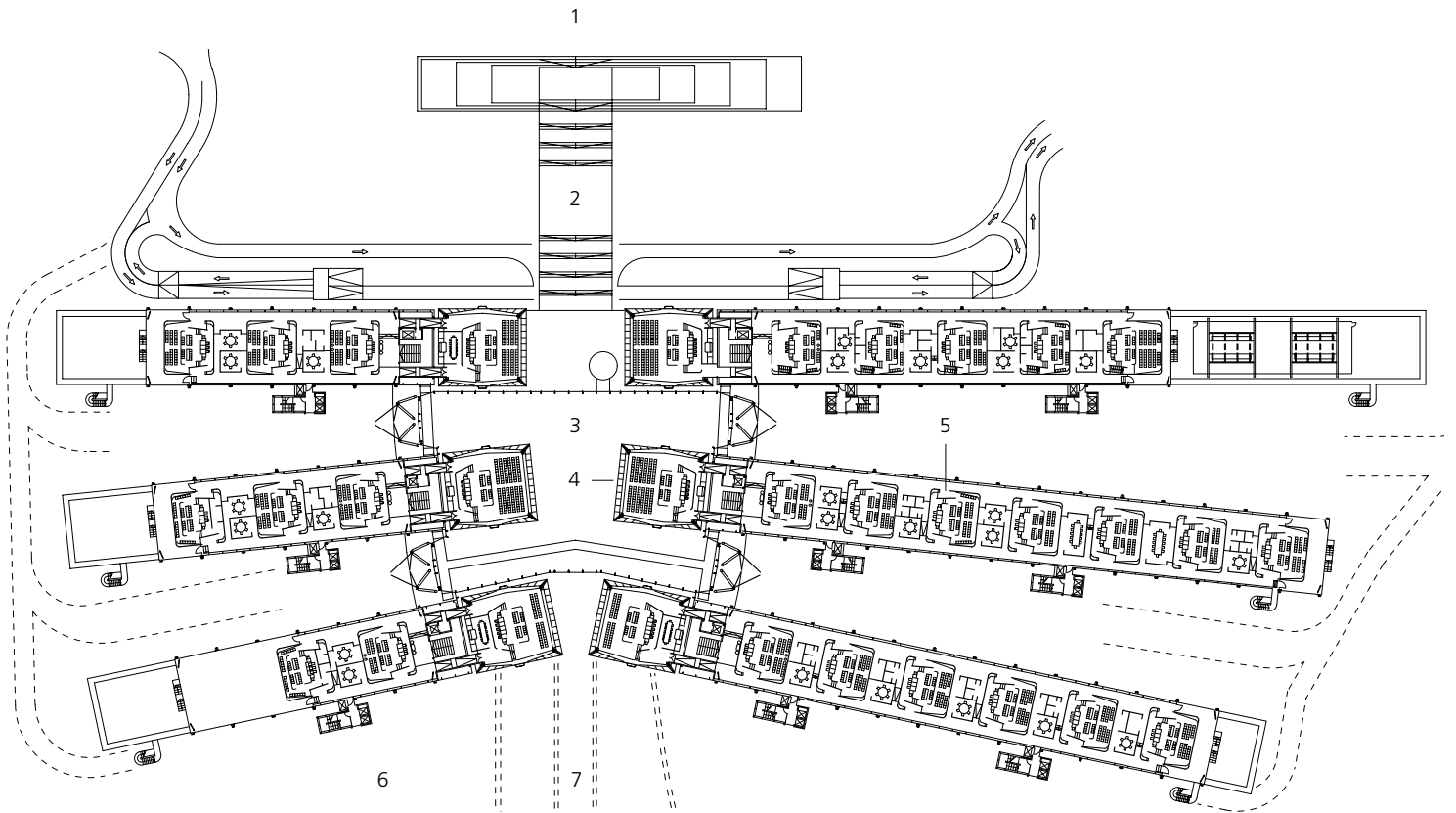

Plan of 3rd floor
Courtroom level
scale 1:1500

1 Bolivarplaats
2 Flight of steps and
main entrance

3 'Salle des pas perdus'
4 Large court room
5 Small court room

6 Park
7 Road passing under the complex
to Boulevard Amerikalei



Visitors enter the building via a broad flight of steps leading up from Bolivarplaats into the grand entrance hall, called the 'Salle des pas perdus'. All the public facilities in the spreading six 'fingers' of the complex (law courts, library, cafeteria etc.) are reached from this central area. The hall is covered by a crystalline roof, its 'facets' largely of glass but interspersed with sixteen triangular stainless-steel assemblies. Responding to the client's wish to project a more 'transparent' image of the work of the Belgian judiciary, the architects defied convention and placed the courtrooms on the top-most

storey, on decks below a visually prominent and highly distinctive roof landscape.

It is the roofs over the six large and 26 smaller courtrooms that give the complex its eye-catching look, echoing the sails of ships past and present passing by on the river. This association is prompted by the unusual shape of the most prominent roof structures, each one made up of four elements, two each for the lower and higher 'sails'. Towering up to 41 metres high, they are an unmistakable landmark on the city skyline.

A broad flight of steps leads up to the glazed entrance hall. The courtrooms, glazed to this hall, are in full view at the top-most level, under the roof. Offices and ancillary rooms are accommodated in the lower storeys.





The glass roof over the entrance hall is interspersed by 16 triangular roof panels in stainless steel.

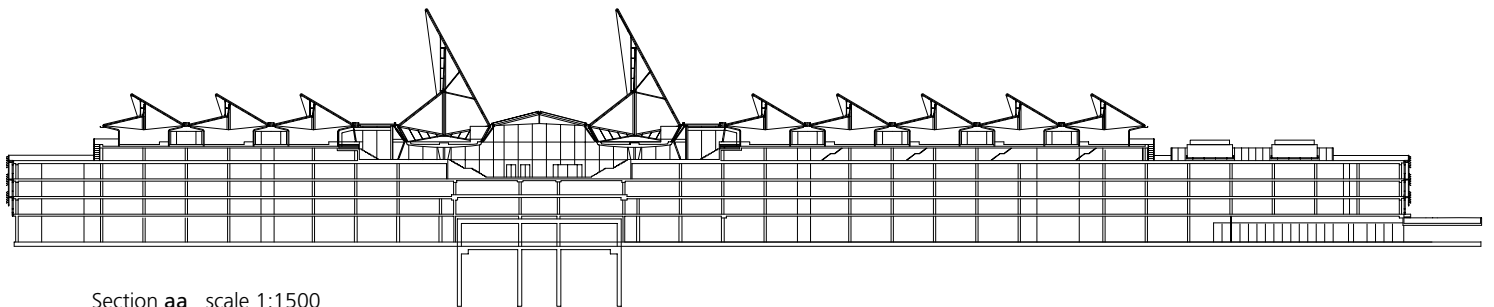

Section aa scale 1:1500

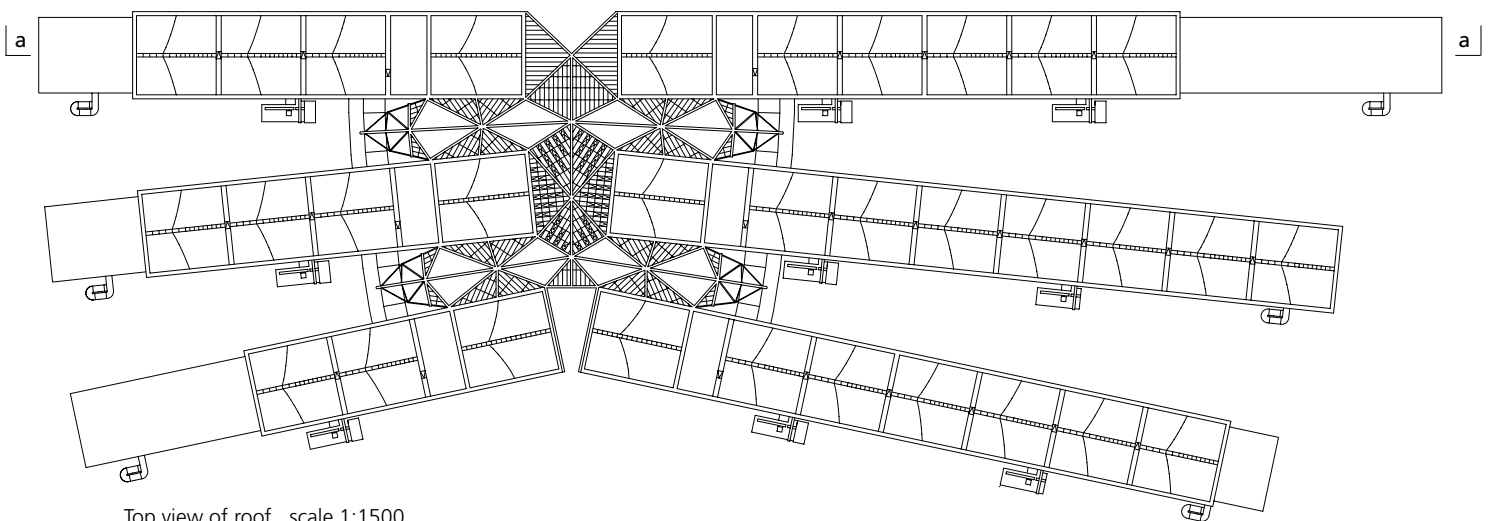

Top view of roof scale 1:1500



By offsetting the small and the large roof cones, space is created for north-west-facing skylights.

In geometric terms, the roof cones over the courts are composed of four hyperbolic paraboloids, rising above a simple rectangular grid. The individual, double-curved roof surfaces are arranged in such a way that the larger peaks rise up above the smaller ones, thus opening up space for a skylight facing northwest. In this way natural light and ventilation is ensured for all the court-rooms. Shade against high-angle sunlight is provided by the overhanging roof edge. An additional narrow strip of skylights runs along the ridge of each roof structure, at the junction of the two panels.

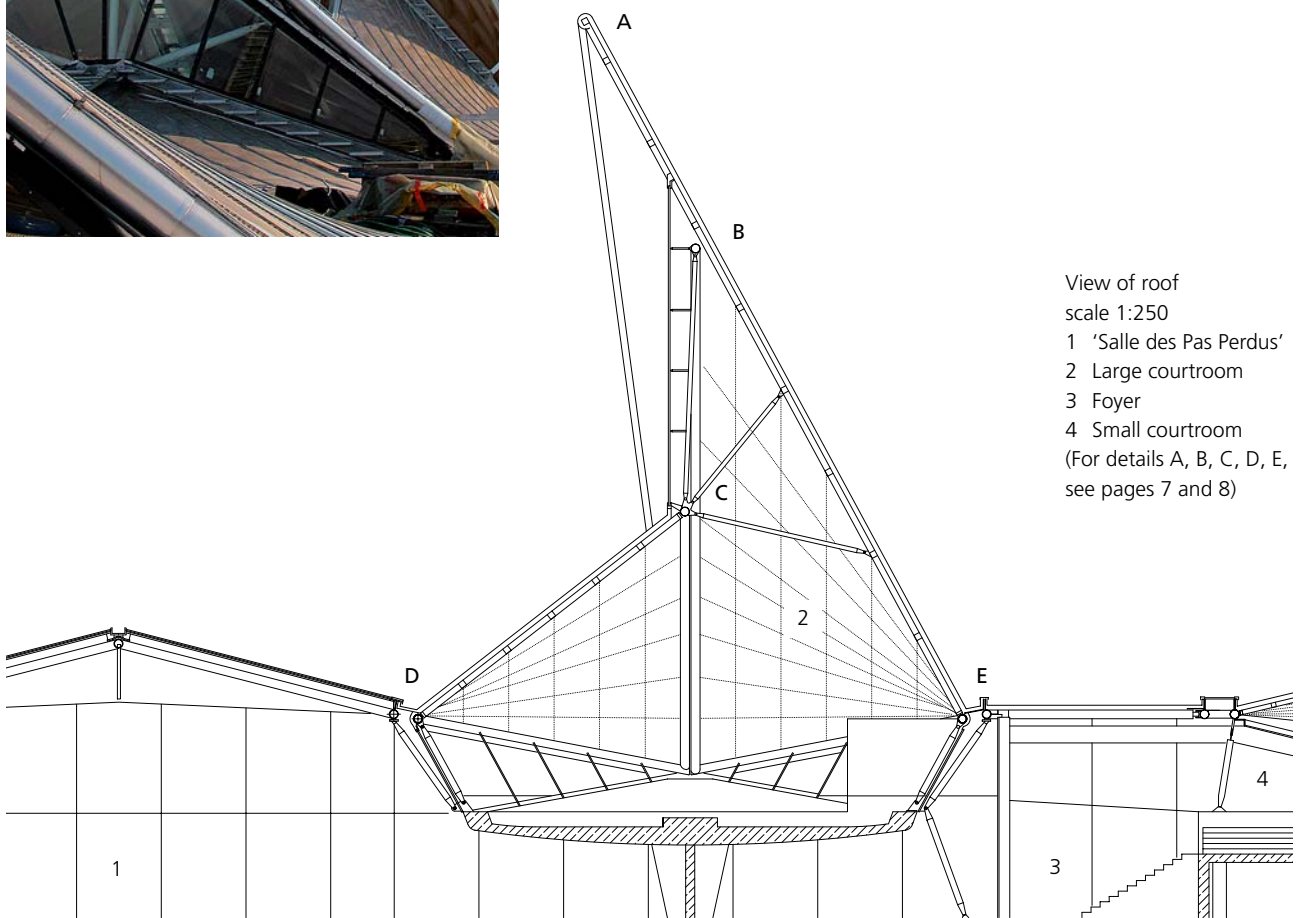

View of roof
scale 1:250
1 'Salle des Pas Perdus'
2 Large courtroom
3 Foyer
4 Small courtroom
(For details A, B, C, D, E,
see pages 7 and 8)



The roof surfaces on the law courts building seem to mimic the rise and fall of waves on water.

Each roof panel is made up of a frame of four tubular steel sections. In between is a shell structure of laminated timber shaped precisely to form a hyperbolic paraboloid. From inside the courtrooms this timber shell remains visible. A vapour barrier is glued on top of the timber shell and above this 120 mm of walk-on mineral wool is laid in two layers with joints offset. The final layer is a continuously welded standing-seam skin of stainless steel. On the smaller roofs the stainless steel is 0.4 mm thick, on the larger ones, 0.5 mm. The stainless steel used is a chromium-nickel-molybdenum alloy

(grade: EN 1.4404) with 2B mill finish. Prefabricated half-cylindrical components in stainless steel were used for the edges of the roof panels. The conical elements on the eaves were welded together in the workshops to lengths of 4 and 5 metres; the joints are concealed on the inside. The gutters are of 1 mm stainless steel, the gutter facings of 1.5 and 2 mm thick material.

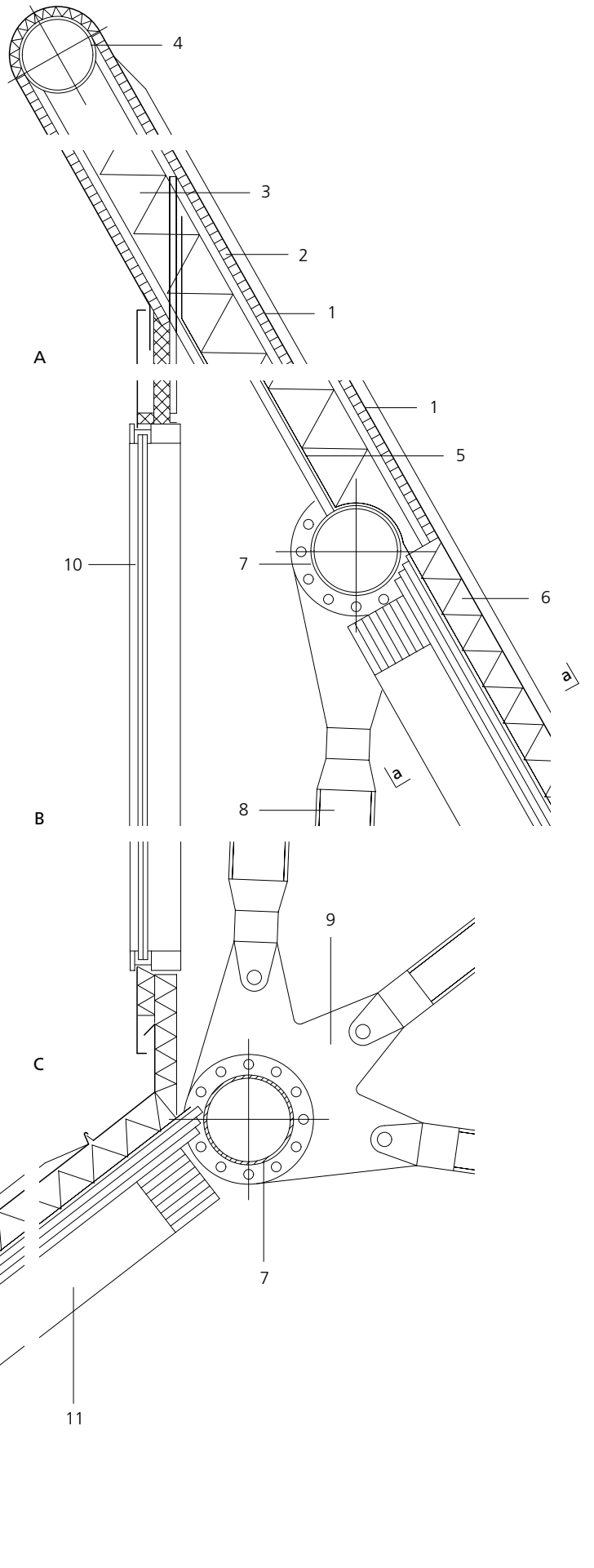

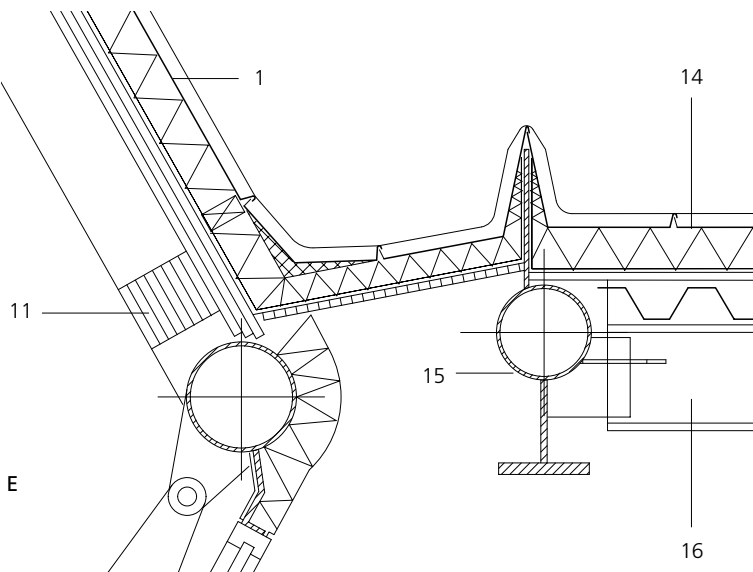
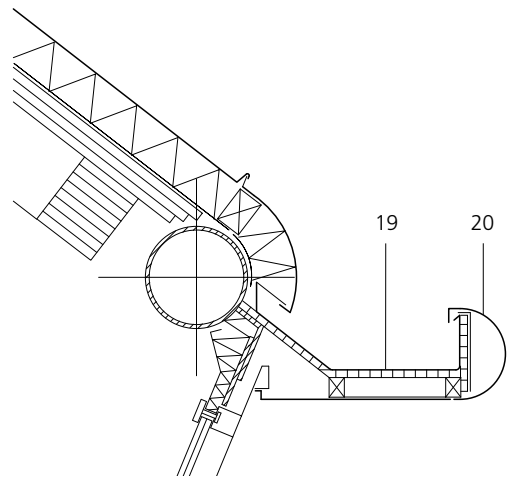
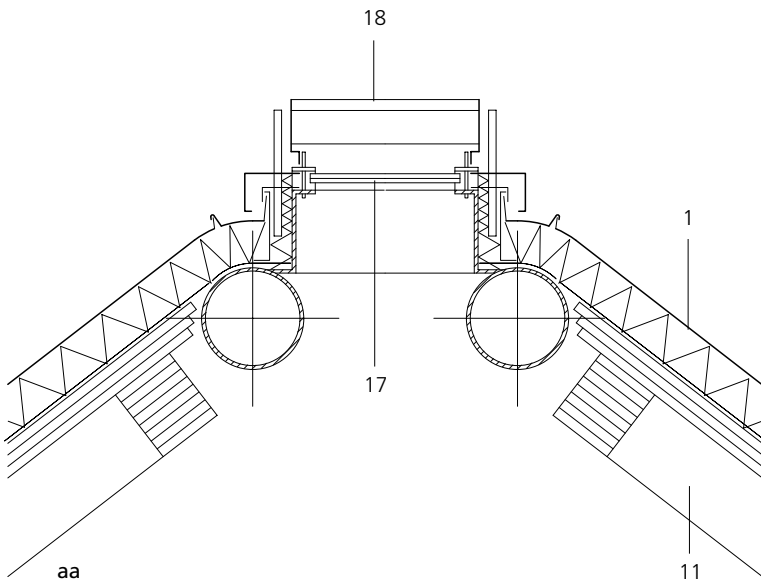

Details of large roof cone scale 1:20

- 1 0.5 mm stainless-steel sheet, with continuously welded standing seams, grade: EN 1.4404, 2B finish
- 2 24 mm multiplex plywood
- 3 200 mm insulation
- 4 Ø 244 x 10 mm steel tube
- 5 vapour barrier
- 6 120 mm insulation
- 7 Ø 273 x 10 mm steel tube
- 8 Ø 139 x 10 mm steel tube
- 9 20 mm steel sheet
- 10 6/20/55.2 mm acoustic security glass
- 11 support grid, 180 x 180 mm laminated timber on three layers of crosswise planking
- 12 glass over the central hall:
10/20/44.2 mm acoustic security glass
- 13 Ø 244 x 10 mm steel tube
- 14 roof structure over the foyer of the courtrooms:
0.4 mm stainless-steel sheet, with continuously welded standing seams
80 mm insulation
vapour barrier
trapezoid steel sheet
- 15 Ø 168 x 10 mm steel tube with 20 mm welded steel plate
- 16 steel girder, IPE 400
- 17 8/20/55.2 mm acoustic security glass
- 18 galvanised steel ladder
- 19 gutter, 1 mm stainless-steel sheet
- 20 cover, 1.5 and 2 mm stainless-steel sheet



The individual components and the roof skin of continuously welded standing-seam stainless steel were prefabricated in an old dockyard down by the river Schelde. Welding, painting, assembly of the timber shell and fitting the roof skin were all carried out in workshops set out in an assembly-line arrangement. Because of the special shape of the roof structures, it was not possible to use parallel sheets for the roofing. The roof strips are sickle-shaped, but differ in dimensions and width profiles from roof segment to roof segment. It was therefore necessary to cut each one to size individually using electrical handshears and a specially prepared template. A simple standing joint was then created on one edge of the strip. The stainless-steel roof trays are mostly fixed to the timber frame using Krabban cleats and stainless-steel bolts. Around 150,000 cleats were used for the 16,000 square-metre stainless-steel roof surface.

An assembly line was set up in an old dockyard to manufacture the 128 elements needed for the roof.



The finished roof panel is lifted onto a barge using a gantry crane.

A 96-m high gantry crane lifted the finished roof elements out of the workshops onto a barge which then transported them down river to a point near to the building site. From there they were moved a short distance on low-loaders, before being hoisted into place with special cranes. Transporting and assembling these giant roofs was a tremendous challenge for all involved, not least because the roof panels over the large law courts each weigh around 24 tonnes and are 24 m high when vertical. After assembly they rise 41 m above the ground. The 'sails' over the 26 small courtrooms are only 11 m high, but still weigh 18 tonnes. The job of prefabricating the roof components in the dockyard and then putting them in position took a good twelve months. While this was going on the smaller roof cones were fitted on site and the connections finished, itself a not inconsiderable challenge.



The prefabricated roof assemblies were transported to the site by barge and then by special truck before being hoisted into position.



Stainless steel offers the corrosion protection necessary in coastal areas, while the continuously welded standing seams give a watertight roof that remains maintenance-free for decades. All of this is achieved in this law courts building despite the difficult geometry of the roof surfaces and the different roof angles. The colour and sheen of stainless steel, reflecting the changing light moods, further enhances the impressive roof landscape of this new iconic landmark in the city of Antwerp.

Euro Inox
Diamant Building, Bd. A. Reyers 80,
1030 Brussels, Belgium
Phone +32 2 706 82 67
Fax +32 2 706 82 69
E-mail info@euro-inox.org
Internet www.euro-inox.org

Client: Regie der Gebouwen, Antwerp, Belgium
Architects: Richard Rogers Partnership, London, England in cooperation with VK Studio, Roeselare, Belgium and Ove Arup & Partner, London, England
Text and layout: Martina Helzel, circa drei, Munich, Germany
Translation: Ingrid Taylor, Munich, Germany
Photos: Katsuhisa Kida, Tokyo; Japan (cover, p. 2, 11); Grant Smith, London, England (p. 1 bottom, p. 3, 4); Willem De Roover, Ghent, Belgium (p. 5, 6, 9, 10); VK Studio, Roeselare, Belgium (p. 1 top, 7, 8)