

Case Study 07 Barcelona Coastal Curtain Wall

Moderate Urban and Industrial Pollution
Moderate Coastal Salt Exposure

The Mapfre Office Tower was completed in 1992 as part of Barcelona, Spain's Olympic village. **(Figure A)** The architect, Ortiz-León Arquitectos, is an environmentally conscious design firm and a member of the Spain Green Building Council. Íñigo Ortiz stated that the building was “designed to very high energy efficiency and environmental standards for its time. It would not be less than silver using the LEED (Leadership in Energy and Environmental Design) green building rating system.”

Barcelona is an important port city. Sea salt and high levels of air borne particulate from loading and unloading ships make the location corrosive. Occasional dust storms originating in the Saharan Desert add to the particulate levels. Locally produced Type 316 (UNS S31600, EN 1.4401, SUS 316) stainless steel and high-efficiency blue glass were used for the exterior.



Figure A The Type 316 stainless steel clad Mapfre Office Tower is separated from the Mediterranean Sea by a park and marina. Despite the corrosive location, the appearance of the stainless steel is unchanged. (Photo Courtesy of ACERINOX)

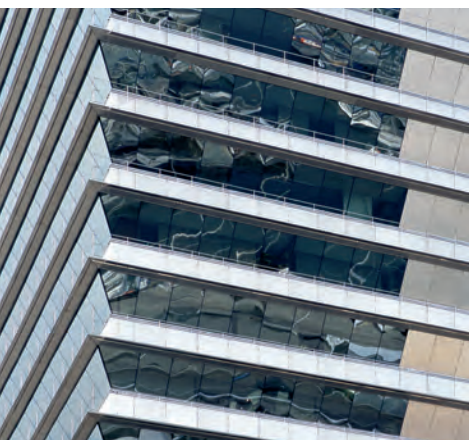

Figures B and C Thoughtful, environmentally conscious design using stainless steel improves energy efficiency, makes cleaning easy, and ensures an attractive appearance over time. (Design detail courtesy of Ortiz-León Arquitectos. Photo Courtesy of Martina Helzel)

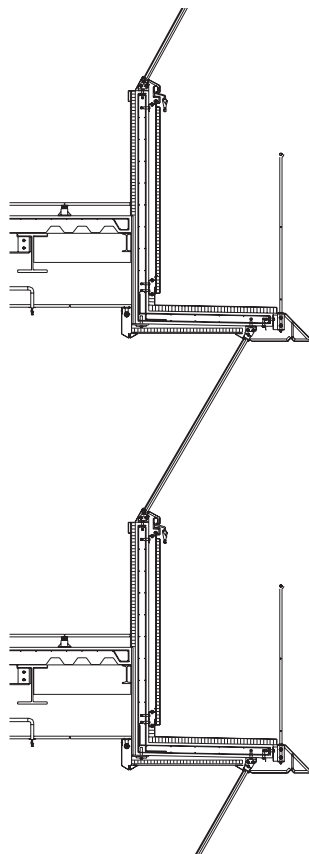

Type 316 stainless steel contains 2% molybdenum, which helps to prevent damage from coastal salt and corrosive pollution. Exterior walkways provide easy access for window and wall panel cleaning at each floor, so that dirt and corrosive contaminants can be removed. **(Figures B and C)** Selection of Type 316 stainless steel and continued regular cleaning will keep the exterior wall panels attractive and corrosion-free over the building's life.

The inwardly sloping, glass windows are screened by the stainless steel panels. The design reduces energy consumption by keeping the building cooler. Most of the stainless steel is sheltered or horizontal which can increase dirt and corrosive deposit accumulation. Smooth matte and polished stainless steel finishes were selected to reduce surface deposit accumulation. The stainless steel panels also reflect natural light into the building.

Stainless Steel Selection Criteria

The IMO A publication, *Which Stainless Steel Should Be Specified for Exterior Applications?*, provides stainless steel selection assistance. The site and design scores below are based on the guidelines in that brochure. Copies can be downloaded from www.imoa.info or ordered by emailing info@imoa.info.

Section 1: Environment

Score = 2

Barcelona, Spain is a port city. The average sulfur dioxide level is 11 µg/m³, which is considered low. In contrast, the average air borne particulate level (PM10) is 117 µg/m³, which is considered high. The high particulate level is attributed to ships loading and unloading products ranging from carbon to grain. In addition, dust storms originating in the Sahara Desert increase air borne particulate levels two or more times per year. Stainless steel performs best when the surface is clean. Particulate in the air can contribute to corrosion in two ways. First, particulate surface deposits can increase the probability of corrosion by creating crevices. Second, some types of particulate can cause metal corrosion. The corrosiveness of the particulate will vary with the cargos that are brought into the port. The score for this environment varies from the equivalent of a low level of urban pollution (0) to a high level of industrial pollution (+4). On average, this environment adds 2 points to the score.

Section 2: Coastal Salt Exposure

Score = 3

Sea salt will corrode most architectural metals and locations within 8 to 16 km (5 to 10 miles) of seawater are at risk for corrosion. If the correct stainless steel is selected and it is properly maintained, it will provide good performance over the life of the building. The Mapfre Office Tower is less than 1.6 km (1 mile) but more than 30 m (100 feet) from the Mediterranean Sea which is a moderate coastal salt exposure (+3).

Section 3: Local Weather Pattern

Score = 1

Weather data provides the following average values: annual low and high temperatures, 4 and 27°C (39 and 81°F); monthly rainfall, 30 to 86 mm (1.2 to 3.4 inches); annual rainfall, 597 mm (23.5 inches); and relative humidity, 63 to 86%. There is insufficient regular rainfall to keep surfaces clean. The combination of low rainfall, moderate to high temperatures, and humidity levels above 50% make the environment more corrosive.

Section 4: Design Considerations

Score = 0

Because stainless steel panels shield the windows to reduce energy consumption, most are either sheltered (+1) or horizontal (+1). Sheltered and horizontal locations are more corrosive, because they accumulate more surface deposits. The smooth surface finishes reduce dirt accumulation and provide better corrosion performance (-1). By selecting smooth finishes, the architect balanced the design score (-1 + 1 = 0).

Section 5: Maintenance Schedule

Score = -3

The high air particulate level makes regular building cleaning necessary to maintain the building's attractive appearance. The architect took this into consideration during design and included cleaning access on each floor. The cleaning crew works throughout the year. If a building or structure is washed monthly, the score is substantially reduced (-3). Water and a pH neutral soap are the only products used to clean the building.

Stainless Steel Selection

Total:

Score = 3

A total score of 3 indicates that Type 316 stainless steel is the most economical choice for this application. It is the preferred stainless steel for most coastal locations when there is no exposure to salt water spray, splashing or immersion. High levels of potentially corrosive air borne particulate, close proximity to the ocean, and sheltered applications make this application corrosive. Smooth surface finishes and regular cleaning are needed to maintain a pristine appearance. If Barcelona's air borne particulate levels decrease in the future, less frequent cleaning would be required.

If the owner had preferred not to clean the stainless steel and did not care about surface deposit accumulation, a more corrosion resistant stainless steel would have been required to prevent corrosion. Under these circumstances, specifying a very smooth finish would provide the best performance and appearance.